

## Features

- Precision supply-voltage monitor
  - 4.63V (STC706L/705, 813L, 708L/707)
  - 4.38V (STC706M/706, 813M, 708M/708)
  - 3.08V (STC706T, 813T, 708T)
  - 2.93V (STC706S, 813S, 708S)
  - 2.63V (STC706R, 813R/706P, 708R)
  - 2.32V (STC706Z, 813Z, 708Z)
  - 2.20V (STC706Y, 813Y, 708Y)
- 200ms reset pulse width
- Debounced TTL/CMOS-compatible manual-reset input
- Independent watchdog timer 1.6sec time-out (not available for STC707/708/708T/708S/R/Z/Y)
- Reset output signal:
  - Active-low only (STC705/706/706T/S/R/Z/Y)
  - Active-high only (STC813L/M/T/S/R/706P)
  - Active-high and active-low (707/708/708T/S/R)
- Voltage monitor for power-fail or low battery warning
- Guaranteed  $\overline{\text{RESET}}/\text{RESET}$  valid at  $V_{CC} = 1.2\text{V}$

## Introduction

The STC706X/813X/708X family microprocessor (μP) supervisory circuits are targeted to improve reliability and accuracy of power-supply circuitry in μP systems. These devices reduce the complexity and number of components required to monitor power-supply and battery functions.

The main functions are:

1. Asserting reset output during power-μp, power-down and brownout conditions for μP system;
2. Detecting power failure or low-battery conditions with a 1.25V threshold detector;
3. Watchdog functions (not for STC708x).

## Applications

- Power-supply circuitry in μP systems

## Contents

Features .....	1
Block Diagram .....	1
Introduction .....	1
Pin Information .....	4
Pin Configuration .....	4
Pin Description .....	4
Functional Description .....	5
Reset Output .....	5
Watchdog Timer .....	5
Manual Reset .....	5
Power-Fail Comparator .....	5
Function Reference Table .....	6
Detailed Specifications .....	7
Absolute Maximum Ratings .....	7
Recommended Operation Condition .....	7
DC Electrical Characteristics .....	8
AC Electrical Characteristics .....	9
Ordering Information .....	10
Mechanical Information .....	11
Notes .....	12

## Block Diagram

Figure 1. Block Diagram of STC706X/707, STC813X/706P

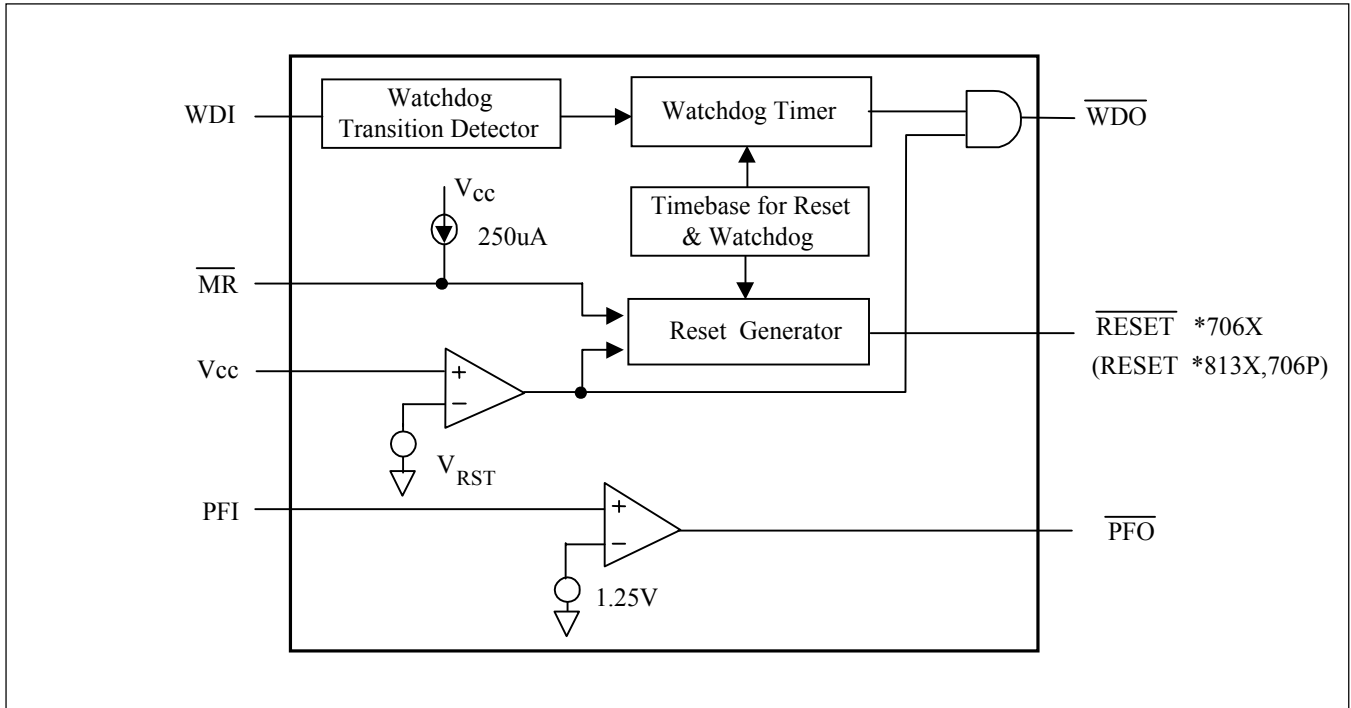
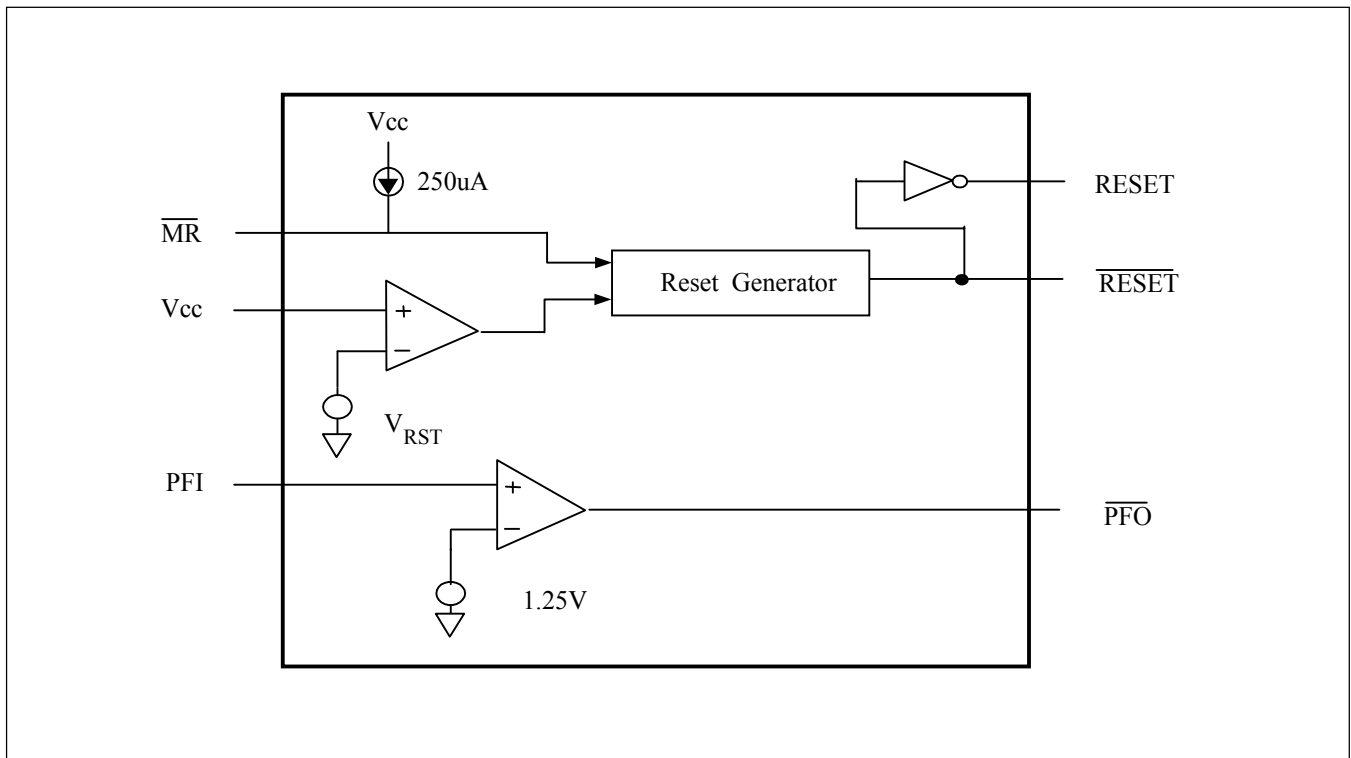

Figure 2. Block Diagram of STC708X / 707



### Pin Information

#### Pin Configuration

Figure 3. Pin Configuration

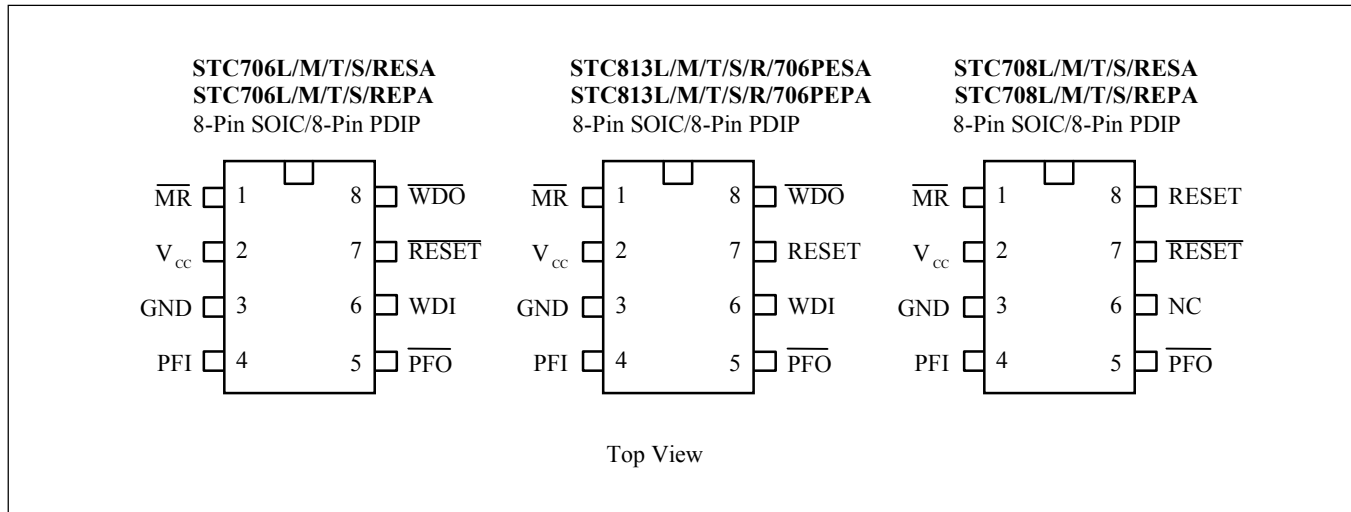

### Pin Description

Table 1. Pin Description

Pin Name	Type	Description
MR	I	<b>Manual-Reset:</b> triggers a reset pulse when pulled below 0.8V, active low. It has an internal 250μA pull-up current and be driven from a TTL or CMOS logic line as well as shorted to ground with a switch.
Vcc	Power	<b>Power Supply</b>
GND	Ground	<b>Ground Reference</b> for all signals
PFI	I	<b>Power-Fail Voltage Monitor Input:</b> When PFI is less than 1.25V, PFO goes low. Connect PFI to GND or Vcc when not used.
PFO	O	<b>Power-Fail Output:</b> it gets low and sinks current when PFI is less than 1.25V; otherwise PFO stays high.
WDI	I	<b>Watchdog Input:</b> If WDI remains high or low for 1.6sec, the internal watchdog timer runs out and WDO goes low. Floating WDI or connecting WDI to a high-impedance three-state buffer disables the watchdog feature. The internal watchdog timer clears whenever reset is asserted. WDI is three-stated, or WDI sees a rising or falling edge.
NC		No Connect
RESET	O	<b>Reset Output pulses:</b> low for 200ms when triggered, and stays low whenever Vcc is below the reset threshold. It remains low for 200ms after Vcc rises above the reset threshold or MR goes from low to high. A watchdog timeout will not trigger RESET unless WDO is connected to MR.
WDO	O	<b>Watchdog Output:</b> pulls low when the internal watchdog timer finishes its 1.6sec count and does not go high again until the watchdog is cleared. WDO also goes low during low-line conditions. Whenever Vcc is below the reset threshold, WDO stays low; however, unlike RESET, WDO does not have minimum pulse width. As soon as Vcc rises above the reset threshold, WDO goes high with no delay.
RESET	O	<b>The inverse of RESET:</b> active high. Whenever RESET is high, RESET is low.

## Functional Description

The STCxxx family can assert reset output during power-up, power-down and brownout conditions for uP system, detect power failure or low-battery conditions with a 1.25V threshold detector and have watchdog functions. Refer to Table 2 for their individual features. The typical application see Figure 4.

### Reset Output

The supervisory circuits can assert reset for a microprocessor during power-up, power-down and brownout to prevent code execution errors.

On power-up, once  $V_{CC}$  reaches about 1.2V,  $\overline{RESET}$  is a guaranteed logic low of 0.4V or less. As  $V_{CC}$  rises,  $\overline{RESET}$  stays low. When  $V_{CC}$  rises above the reset threshold, an internal timer releases  $\overline{RESET}$  after about 200ms.  $\overline{RESET}$  pulses low whenever  $V_{CC}$  drops below the reset threshold (brownout condition). If brownout occurs in the middle of a previously initiated reset pulse, the pulse continues for at least another 140ms.

On power-down, once  $V_{CC}$  falls below the reset threshold,  $\overline{RESET}$  stays low and is guaranteed to be 0.4V or less until  $V_{CC}$  drops below 1V.

The STC813x and STC706P active-high  $\overline{RESET}$  output is simply the complement of the  $\overline{RESET}$  output, and is guaranteed to be valid with  $V_{CC}$  down to 1.2V. Some μPs, such as Intel's 80C51, require an active-high reset pulse.

## Watchdog Timer

The watchdog circuit monitors the μP's activity. If the μP does not toggle the watchdog input (WDI) within 1.6sec and WDI is not in high impedance,  $\overline{WDO}$  goes low. As long as  $\overline{RESET}$  is asserted or the WDI input is in high impedance, the watchdog timer will stay cleared and will not count. As soon as reset is released and WDI is driven high or low, the timer will start counting. Pulses as short as 50ns can be detected.

Typically,  $\overline{WDO}$  will be connected to the non-maskable interrupt input (NMI) of a μP. When  $V_{CC}$  drops below the reset threshold,  $\overline{WDO}$  will go low whether or not the watchdog timer has timed out yet. Normally this would trigger an NMI interrupt, but  $\overline{RESET}$  goes low simultaneously, and thus overrides the NMI interrupt. If WDI is left unconnected,  $\overline{WDO}$  can be used as a low-line output. Since floating WDI disables the internal timer,  $\overline{WDO}$  goes low only when  $V_{CC}$  falls below the reset threshold, thus functioning as a low-line output.

## Manual Reset

The manual-reset input ( $\overline{MR}$ ) allows reset to be triggered by a push-button switch. The switch is effectively debounced by the 140ms minimum reset pulse width.  $\overline{MR}$  is TTL/CMOS logic compatible, so it can be driven by any logic reset output.

## Power-Fail Comparator

The power-fail comparator will send out a Low signal once it detects a voltage lower than 1.25V. It can be used for various purposes because its output and non-inverting input are not internally connected. The inverting input is internally connected to a 1.25V reference.

**Figure 4. Typical Application Circuit**

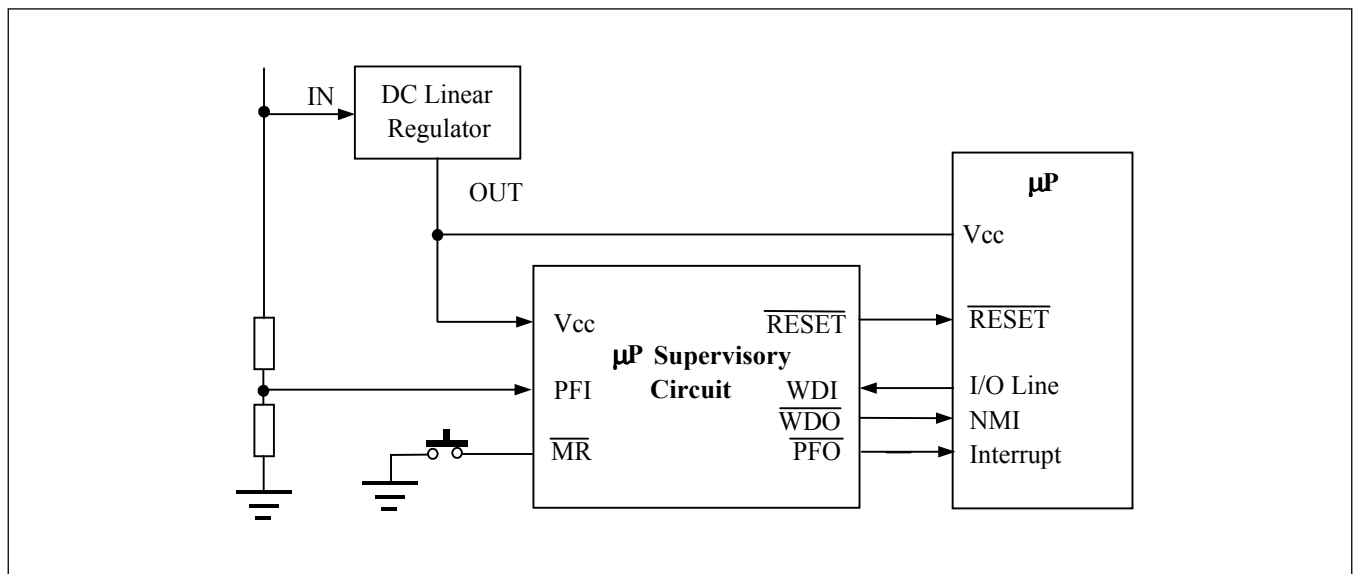

## Function Reference Table

**Table 2. Function Table of PT7A75xx Family**

Part No.	Reset Threshold	Reset Active Low or High	Nom. Reset Time (ms), $t_{RS}$	Nom. Watch dog Time (sec), $t_{WD}$	Power Fail Comp.	Manual Reset Input
STC706L/705	4.63V	LOW	200	1.6	1.25V detector	Yes
STC813L	4.63V	HIGH	200	1.6	1.25V detector	Yes
STC708L/707	4.63V	LOW, HIGH	200	unavailable	1.25V detector	Yes
STC706M/706	4.38V	LOW	200	1.6	1.25V detector	Yes
STC813M	4.38V	HIGH	200	1.6	1.25V detector	Yes
STC708M/708	4.38V	LOW, HIGH	200	unavailable	1.25V detector	Yes
STC706T	3.08V	LOW	200	1.6	1.25V detector	Yes
STC813T	3.08V	HIGH	200	1.6	1.25V detector	Yes
STC708T	3.08V	LOW, HIGH	200	unavailable	1.25V detector	Yes
STC706S	2.93V	LOW	200	1.6	1.25V detector	Yes
STC813S	2.93V	HIGH	200	1.6	1.25V detector	Yes
STC708S	2.93V	LOW, HIGH	200	unavailable	1.25V detector	Yes
STC706R	2.63V	LOW	200	1.6	1.25V detector	Yes
STC813R/706P	2.63V	HIGH	200	1.6	1.25V detector	Yes
STC708R	2.63V	LOW, HIGH	200	unavailable	1.25V detector	Yes
STC706Z	2.32V	LOW	200	1.6	1.25V detector	Yes
STC813Z	2.32V	HIGH	200	1.6	1.25V detector	Yes
STC708Z	2.32V	LOW, HIGH	200	unavailable	1.25V detector	Yes
STC706Y	2.20V	LOW	200	1.6	1.25V detector	Yes
STC813Y	2.20V	HIGH	200	1.6	1.25V detector	Yes
STC708Y	2.20V	LOW, HIGH	200	unavailable	1.25V detector	Yes

## Mechanical Information

Figure 7. 8-Pin SOIC

